

TORRE SOLAR DE ILUMINACION

MOVIL 90000Lm

Súper brillante

FHS300M



INTERNATIONAL OFFICES FH SOLAR & LED IBERICA

FH SOLAR & LED IBERICA S.L

Oficina Central**
Núñez Morgado 5
28036 Madrid
Tel.+34 913235993
Mv.+34 600027027
info@fhsolarled.com
España /Latam

FH SOLAR & LED MEXICO S.A DE C.V

Montecito 38
Col. Nápoles 03810
Tel.+52 5536888031
Tel.+52 5584217977
W : +52 5511599589
Ciudad De México
info@fhsolarled.com
México

FH SOLAR & LED IBERICA S.A.S

Carrera 27 N° 30-16
Tel.: +57(2) 2253517
Cel:+57 3009293667
W : +34 600027027
Tulua , Valle del Cauca
info@fhsolarled.com
Colombia



Tecnología



Libre de Combustibles
contaminantes



Fabricada para
todo tipo de clima



Gran autonomía
operativa

Disminución de
costos operativos



Libre de contaminación
auditiva



FHS300M



victron energy
BLUE POWER



Available on the
Mac app

Download for
Windows

Download on the
App Store

Get it on
Google Play



FHS300M

INFORMACION TECNICA

Sistema básico :

Marca:	GREENPOWER
Nombre:	Torre de luz solar
Modelo:	FHS300M
Material:	Acero Q235
Tipo:	Para exteriores
Dimensión:	Largo×Ancho×Alto 2300×1600×2200 (mm) 7.5 × 5,2 × 7 (pies)
Transporte:	3200×1600×2500 (mm) 10,5 × 11 × 21 (pies)
Operando:	3250×4400×9000 (mm) 10.5 × 11 × 29,5 (pies)
Peso:	1400 kg / 3086 libras
Voltaje del sistema:	CC48V
Temperatura de trabajo	-20°C~50°C / -4°F~122°F

Foto :



Sistema Solar :

Panel Solar :	3 x435W Sunpower Maxeon® o similar (Monocristalino)
Voltaje :	DC39V
Tiempo de carga:	4 a 6 Horas

Sistema de Baterías :

GEL:	6 × 200Ah Ciclo profundo libre de mantenimiento
LFP Battery(Litio):	Opcional LiFePO4 BATTERIES
Voltaje:	CC12V
Serie y Paralelo:	2 en serie, luego en paralelo
Capacidad de potencia:	14400W·h

Sistema de Iluminación

LED PHILIPS:	4 X 150W Módulo Tipo para exteriores
Clase de protección:	P65 90000 lm
Lúmenes:	20° 40° 60° 90° 110°
Ángulo de haz:	DC48V
Voltaje:	19,2 horas por batería
Tiempo de ejecución:	13 horas por días

Sistema de Control:

Controlador solar:	VICTRON
SmartSolar MPPT:	150/35
Eficiencia:	95%+
Monitor de batería:	SmartShunt
Monitor:	Cerbo GX + táctil
Enrutador	4G y WiFi
Detección y protección:	Cortocircuito Sobrecarga Alto voltaje Alta temperatura Amanecer
Temporizador:	Aislador de batería luz encendida y apagada Mástil arriba-abajo Rotación e inclinación
Toda la máquina:	

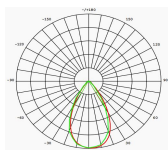

60° Optical



Sistema de Mastil:

Cuerpo:	Acero Q235 Galvanizado
Cierre:	Acero inoxidable 304
Cuerda de alambre:	Acero inoxidable 316. / 8mm
Tipo:	Cuadrado / Telescópico 6,5 m / 21,3 pies
Altura:	9
Sección:	360 ° eléctrico
Inclinación:	90° eléctrico
Cable de resorte:	Fuente de alimentación
Método de elevación:	Manual /Eléctrico(Opcional)
Carga recomendada:	5 kg ~ 70 kg / 11 libras ~ 154 libras
A prueba de viento:	117 km/h/73 mph

Sistema de Trailer :

Estándar:	EE. UU./AU/UE
Enganche de remolque:	Tipo de anillo de 50 mm / 2"(Opcional ALKO)
Luz del remolque:	7 pines
Rueda Jockey:	200 mm / 8"
Eje:	Una /Suspensión Freno de golpe
Neumático:	2 × 15 pulgadas
Calzo de rueda:	2
Orificio de montacargas:	2
Balancín:	4 × manual/galvanizado
Garantía:	3 Años

Dimensiones

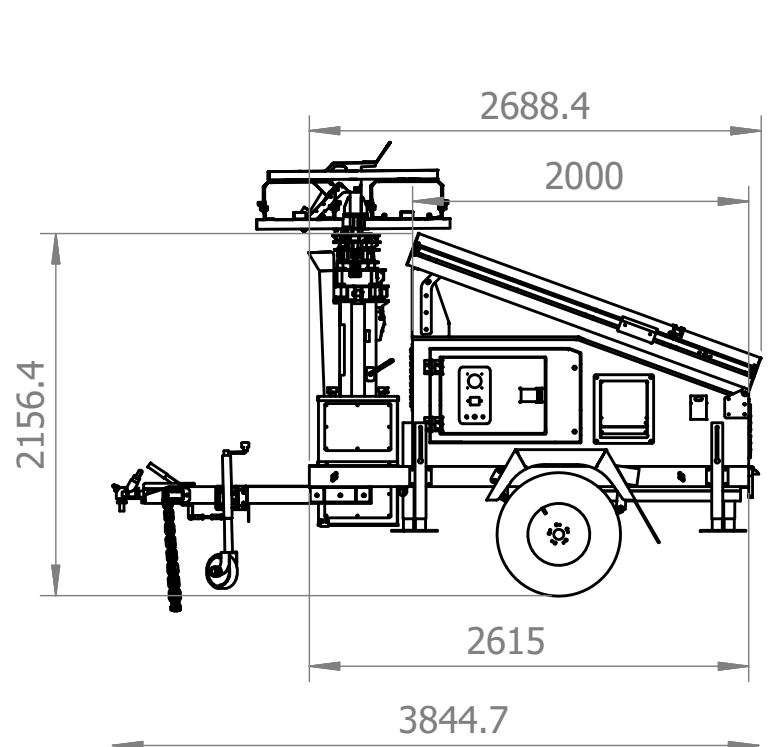
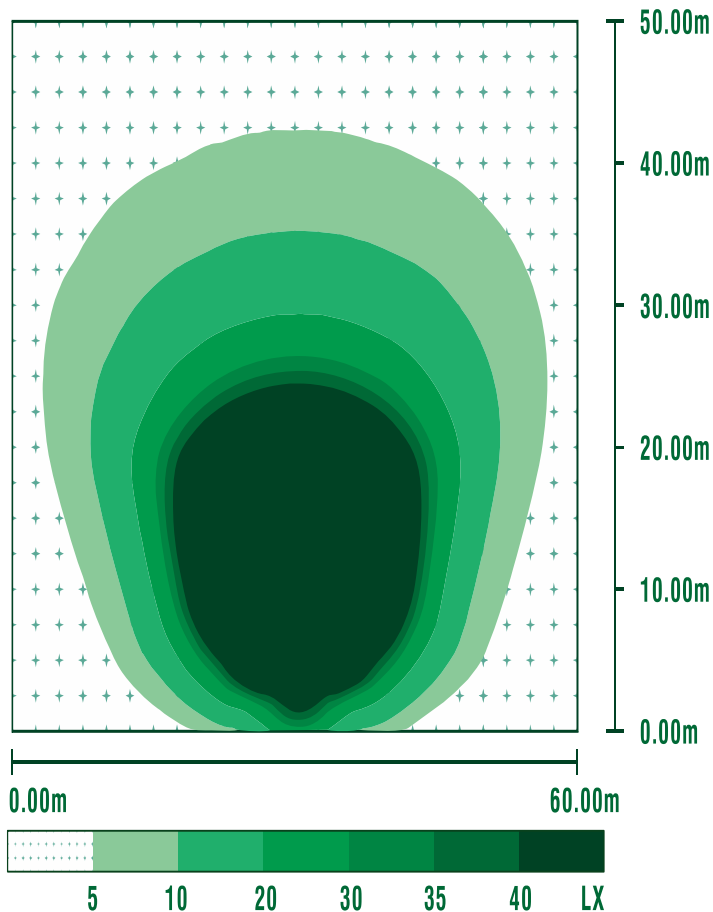



FHS300M



**SUPER-
MACHINE**