

# FHC9700L

## High Power LED Explosion proof Floodlight



### FHC9700L series

### Characteristics



Ex marking: Ex db IIC T5/T4/T3 Gb  
Ex tb IIIC T95°C/T130°C/T195°C Db

- A full range of high conductivity material accelerate convection cooling structure, effective guarantee long-term use in high temperature environments.
- Variety of light distribution, variety of installation types, an effective solution to beautify workshop and device platform.
- It adopts imported light source, no dark spot, energy-saving is 60% more than Metal Halide Lamp.
- AC-DC wide voltage driver, power factor above 0.98.
- The rapid replacement of power without welding can be realized.
- The adjustable locking device on the bracket can tightly fix the lamp to any desired angle, making the lamp resist to harsh vibration.
- It is made using aluminum housing, all exposed fasteners adopt 304 stainless steel. Using high-tech anti-corrosion surface treatment technology, suitable for hazardous working areas.
- Windward area is only 30% of the traditional lamp, suitable for high-altitude winds area.
- Intelligent control functions can be realized.

### Application

- Zone 1, zone 2; zone 21, zone 22
- Suitable for Low installation height in Moist corrosive environment ,such as offshore drilling platform, Oil Terminal, etc.
- Ideal to be used in the environment of flammable gas, steam and dust environment, such as Petrochemical Plant, Chemical Plant, Coal Washery, Pharmaceutical Factory, etc.
- Areas for high demand of high temperature performance.



### Main Specification



Item	Technical Parameters
Input voltage (V)	90~305VAC
Rated frequency	50Hz / 60Hz
Light source	LED
Life time (h)	50,000
CRI (Ra)	70 (80 optional)
CCT	5000K(3000K/4000K optional)
Cable Entry	M20×1.5, M25×1.5, G3/4", NPT1/2", NPT3/4"
Dimension (mm)	300×202×332
Net weight (kg)	6.3



# FHC9700

## High Power LED Explosion proof Floodlight



### Drawing of dimension (Dimensions in mm)

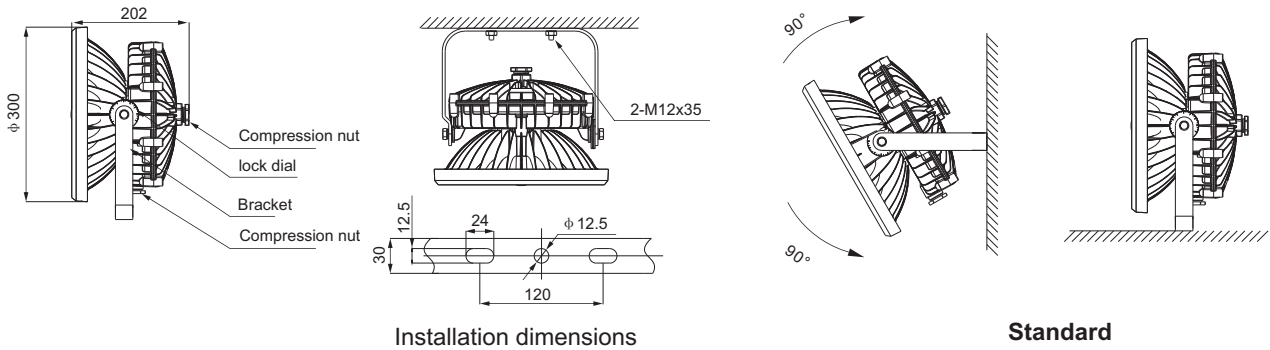

### Ordering Reference

Ordering reference	Picture	Rated Wattage (W)	Light output (lm)	Space height ratio	Mounting height (m)	Light distribution Curve(1000cd/lm)	Equivalent to
							MH
FHC9700-L60-40°		60W	6600	0.7	8~12m		150W
FHC9700-L80-40°		80W	8600				175W
FHC9700-L100-40°		100W	11200				250W
FHC9700-L120-40°		120W	12900				> 250W
FHC9700-L150-40°		150W	15600				400W
FHC9700-L180-40°		180W	16800				> 400W
FHC9700-L60-60°		60W	6600	0.9	8~12m		150W
FHC9700-L80-60°		80W	8600				175W
FHC9700-L100-60°		100W	11200				250W
FHC9700-L120-60°		120W	12900				> 250W
FHC9700-L150-60°		150W	15500				400W
FHC9700-L200-60°		200W	21900				> 400W



# FHC9700

## High Power LED Explosion proof Floodlight



### Ordering Reference

FHC9700-L60-80°		60W	6800	1.35	8~12m		150W
FHC9700-L80-80°		80W	8800				175W
FHC9700-L100-80°		100W	11500				250W
FHC9700-L120-80°		120W	13200				>250W
FHC9700-L150-80°		150W	15900				400W
FHC9700-L200-80°		200W	22300				>400W
FHC9700-L60-100°		60W	6800	1.4	8~12m		150W
FHC9700-L80-100°		80W	8900				175W
FHC9700-L100-100°		100W	11600				250W
FHC9700-L120-100°		120W	13400				>250W
FHC9700-L150-100°		150W	16100				400W
FHC9700-L200-100°		200W	22700				>400W
FHC9700-L60-60°×80°		60W	6800	1.25	8~12m		150W
FHC9700-L80-60°×80°		80W	9000				175W
FHC9700-L100-60°×80°		100W	11800				250W
FHC9700-L120-60°×80°		120W	13600				>250W
FHC9700-L150-60°×80°		150W	16400				400W
FHC9700-L200-60°×80°		200W	22100				>400W
FHC9700-L60-90°×110°		60W	6600	1.75	8~12m		150W
FHC9700-L80-90°×110°		80W	8400				175W
FHC9700-L100-90°×110°		100W	11000				250W
FHC9700-L120-90°×110°		120W	12600				>250W
FHC9700-L150-90°×110°		150W	15200				400W
FHC9700-L200-90°×110°		200W	20900				>400W



FH SOLAR & LED IBERICA S.L  
 Núñez Morgado 5 | 28036 Madrid  
 Tel. +34 913235993 | +34 600027027  
 info@fhsolarled.com  
 Spain · Colombia · México

