

LED HIGH BAY LIGHT SERIES FH-INDUSTRIAL LED

**ULTRA
HD**



Areas of application

- Warehouse
- Garages
- Workshop
- Commercial Facilities
- Aisles (Open & Stock)
- Field Houses & Gymnasiums

Product Benefits

- Light efficiency up to 175lm/w
- Up to 100,000hrs @L70, low maintenance cost
- World class, approbated quality components (LEDs /Driver /etc.)
- Smooth body would greatly diminish dust accumulation
- Six mounting options, post top, pendant, suspension, side entry and etc
- 5 years warranty



HIGH BAY LIGHT INDUSTRIAL LED



LED HIGH BAY LIGHT SERIES FH-INDUSTRIAL LED



Product Datasheet

Specifications:

Model No	FH-T20-30HB	FH-T20-30HB*	FH-T20-50HB	FH-T20-50HB*	FH-T20-80HB
Nominal Wattage	30W	30W	50W	50W	80W
Efficiency	155 lm /w	175 lm /w	160 lm /w	175 lm /w	165 lm /w
Lumen	4650 lm	5250 lm	8000 lm	8750 lm	12400 lm
Model No	FH-T20-80HB*	FH-T20-100HB	FH-T20-100HB*	FH-T20-120HB	FHT20-1S0HB
Nominal Wattage	80W	100W	100W	120W	150W
Efficiency	165 lm /w	150 lm /w	160 lm /w	150 lm /w	150 lm /w
Lumen	13200 lm	15000 lm	16000 lm	18000 lm	22500 lm

- Above values are calculated based on the product with CCT over 3000K, values of 3000K are 5% lower than above values.
- Luminous efficacy values are different when the same model with different optical lenses.
- Values shown are subject to $\pm 5\%$ tolerance.
- Model No with "*" means high efficiency version.

Electrical Data:

Nominal Voltage	AC 100-240V /277V /60Hz
LED	Lumileds
Driver	Inventronics /Other brands on request
Power Factor (PF)	>0.95
THD	<15
SPD	10KV (Default) /20KV (available on request)
Optics	60°/90°/120°
Standard Deviation of Color Matching	<5 SDCM
CRI	Ra>70 (Default) /Ra>80
CCT	3000K, 4000K, 5000K, 5700K

General Data

Body Material	High pressure die-cast aluminum
Housing Color	Gray (RAL9007) /Black (available on request)
Cover Material	Tempered glass
Lens Material	UV-resistant Polycarbonate
Working Environment	-40° C - +50° C, 10%-90%RH
Lifespan L70 at 25° C	>100,000 h
Mounting Type	Hook Loop
Dimmable	1-10V Dimming (Default) /Timer Dimming
Protection Class	Class I (Default) /Class II
Standards	CE, RoHS, ENEC, CB, LM79, LM80, TM-21, IP66, IK08/IK10
Available on request	Motion sensor, NTC, OLC, DALI Dimming, Zigbee /Lora Control



HIGH BAY LIGHT INDUSTRIAL LED



LED HIGH BAY LIGHT SERIES FH-INDUSTRIAL LED



Product Datasheet

Light Distributions

Order reference

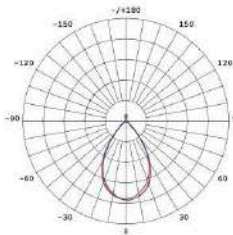
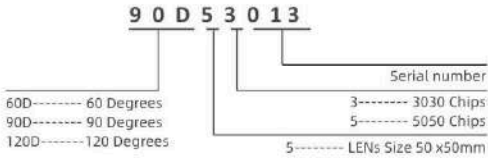

60D53012

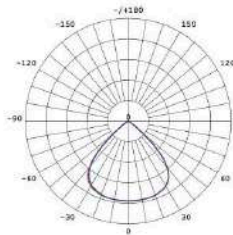

90D53013

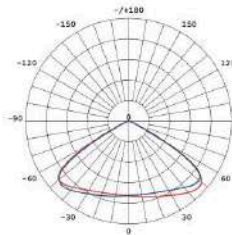

120D53014

Dimension

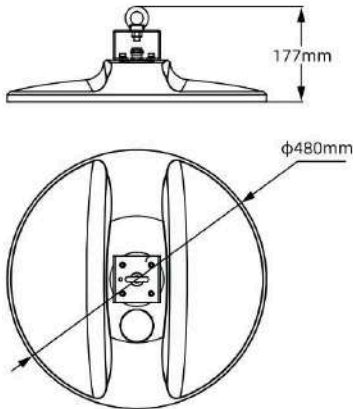

Product Information



Packing Type	Package Dimension (mm)	Fixture Weight (kg)	Package Weight (kg)
1unit /ctn	495*495*170	6.3	7.3

HIGH BAY LIGHT INDUSTRIAL LED



FH SOLAR & LED IBERICA S.L. Calle Serrano 110 Planta 1ª 28006 Madrid
Tel.+34 913235993 | +34 600027027
info@fhsolarled.com
Spain . Colombia . México .Latam



www.fhsolarled.com